



ALUMINIUM
JOINERY
MANUFACTURER

 100% HANDMADE - PREMIUM QUALITY



A WORLD OF
**ARCHITECTURALLY
INTERESTING STRUCTURES**



PRODUCTION OF MODERN ALUMINIUM JOINERY

Customer satisfaction is our top priority - that is why we always take pride in the quality of our products and efficient service. Based on years of experience and process optimisation, we offer our customers an individual and comprehensive approach to each project.

Fulfilling our customer's needs and guaranteed product quality is an essential basis for success - which is why we consistently comply with European technical standards and strictly adhere to certification requirements. Every year, our company is audited by an external, autonomous certification body.

YEARS OF EXPERIENCE

Many years of experience and technical expertise allow us to professionally carry out each order in accordance with the customer's expectations. Our qualified staff are always on hand to provide assistance and advice.

HIGH QUALITY COMPONENTS

We manufacture aluminium joinery from the highest quality materials produced by world-class industry leaders. Aiming at innovative solutions we use a wide range of aluminium systems.

FACTORY PRODUCTION CONTROL

In order to maintain the highest quality goods, we check the components and finished products daily, analyse the production process and remember the best solutions.

FREEDOM TO CHOOSE SHAPE AND STYLE



WHY ALUMINIUM JOINERY?

Aluminium is the ideal material for modern building concepts. Despite its light weight, aluminium structures guarantee:

- top quality and outstanding durability
- excellent thermal insulation
- effective protection against burglary
- reliable protection against weather and noise
- timeless comfort and functionality

Styles, shapes, dimensions, opening methods... it's all up to the customer.

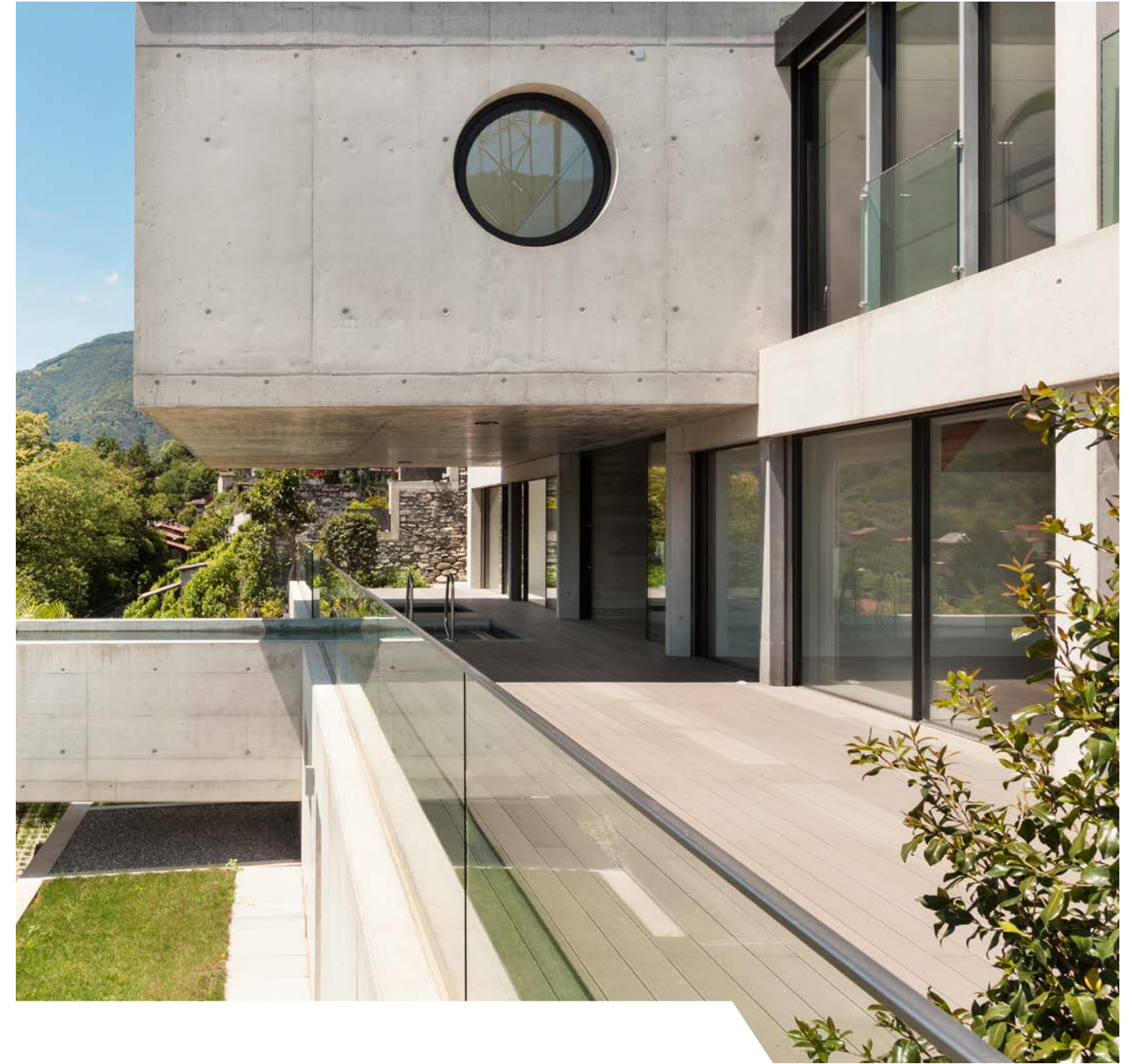

SOLUTIONS THAT INSPIRE

SOLUTIONS

We offer a wide range of design and joinery solutions to match any style of building.

DESIGN

A variety of sophisticated profile shapes - this is the element that makes our window and door joinery stand out in terms of appearance and aesthetics to the highest degree.

ENERGY EFFICIENCY

Using innovative system solutions, we offer windows and doors aimed at reducing energy consumption as much as possible.

COMFORT

The technological solutions enable us to create huge glass surfaces that maximise the amount of sunlight inside, creating a sense of ambiance for the home owner.



WINDOWS

INNOVATIVE SOLUTIONS, MODERN DESIGN

ENERGY-EFFICIENT WINDOWS

The most desired feature for currently manufactured windows is their very low thermal transmittance. We offer joinery for the entire construction with a coefficient of U-value starting from 0,6 W/(m²*K).

HIDDEN SASH WINDOWS

This means that the window sash is invisible from the outside because it is "hidden" behind the frame profile. The construction gives an impression of being slim and light, and the opening and fixed sections look the same from the outside.

PIVOT, SLIDING OR OUTWARD OPENING WINDOWS

This type of window is an interesting alternative to classic solutions and an excellent choice for people who value comfort. Windows of this type are particularly popular in England, Ireland and on Scandinavian markets.

UNUSUALLY VISUAL WINDOWS

Sophisticated profile shapes, slender contours, rounded glazing beads are just some of the possible solutions. Our joinery can find its place in any architectural style.

EXAMPLES OF DIFFERENT WINDOW OPENING ELEMENTS

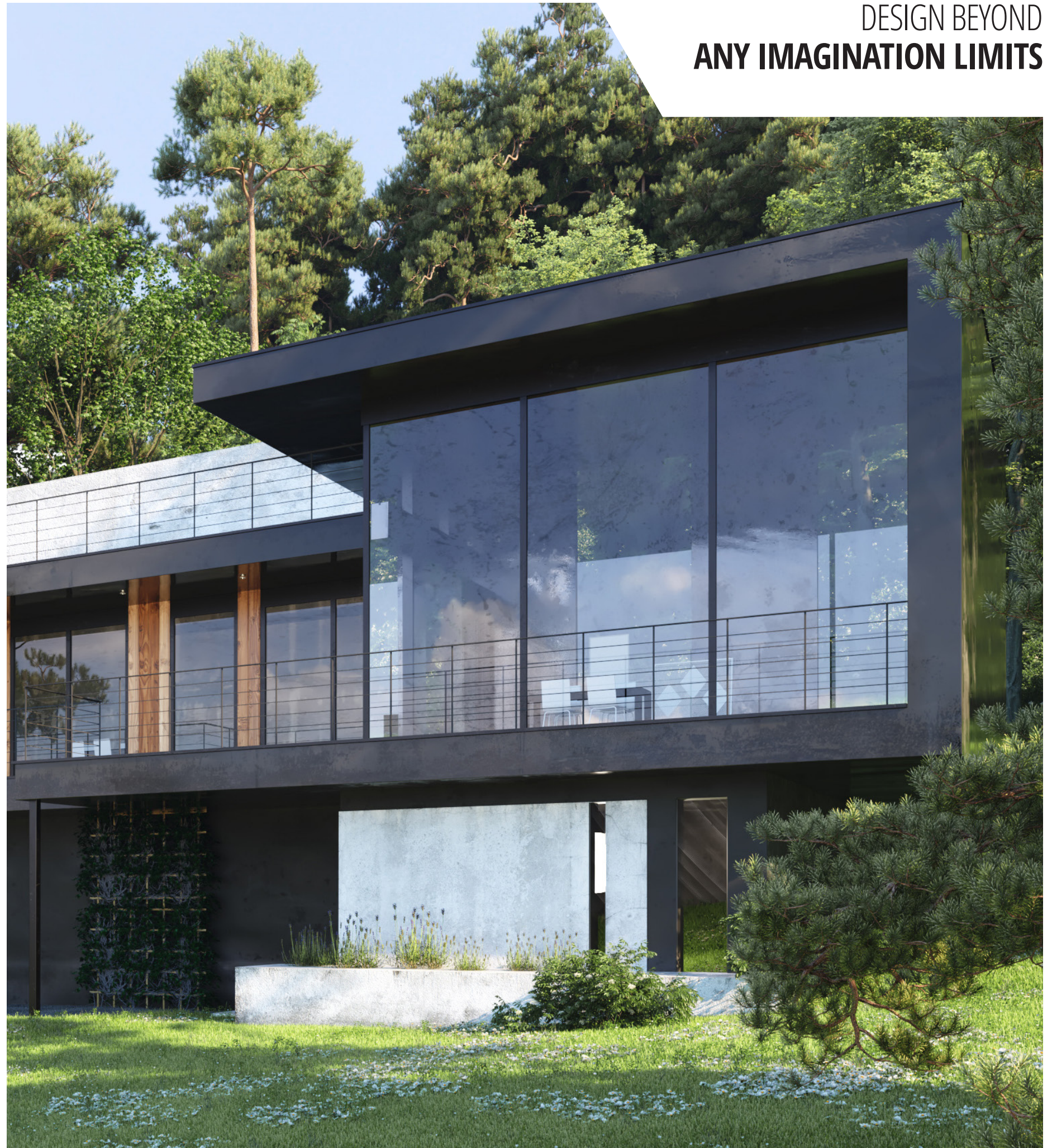
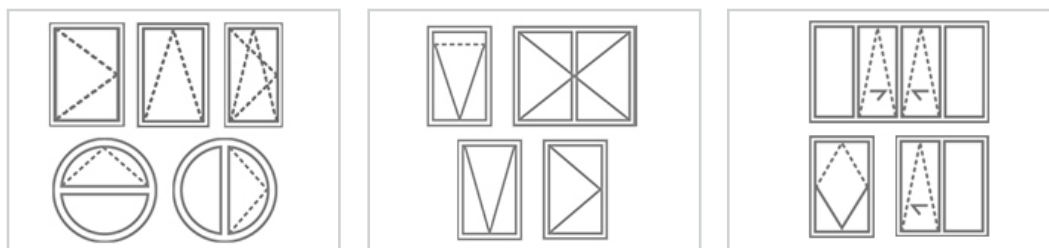

ENERGY EFFICIENCY

ALUMINIUM SYSTEMS WITH INCREASED THERMAL INSULATION ARE IDEAL FOR PASSIVE BUILDINGS

REYNAERS MASTERLINE 10

This is one of the latest and most innovative window and door systems that aims to maximise energy efficiency. This system has the best parameters in its class combined with a variety of opening types and at the same time is unique in its versatility as it has connecting profiles for sliding systems and curtain walls. **The windows are Passive House certified.**



97-107	Frame installation depth (mm)	up to 2000Pa class C5	Wind load resistance
107	Sash installation depth (mm)	up to 900Pa klasa E900	Watertightness
up to 600Pa class 4	Air permeability	46 (-1;-4)	Acoustic insulation (dB)

OPERABLE WINDOWS AS FIXED

TO MEET THE INDIVIDUAL CUSTOMER'S NEEDS THE OPERABLE WINDOW APPEARS SIMILAR FROM THE OUTSIDE TO A FIXED WINDOW

REYNAERS MASTERLINE 8

It is a system with a high level of thermal insulation with the possibility of using standard and so-called "hidden" sashes. The insulation solution used in the system provides the highest degree of stability, watertightness and airtightness, it also allows the use of triple glazing. **Four aesthetic variants** make it possible to match any architectural style.



77-87	Frame installation depth (mm)	up to 1600Pa class C4	Wind load resistance
80-87	Sash installation depth (mm)	up to 900Pa class E900	Watertightness
up to 600Pa class 4	Air permeability	45 (-1;-4)	Acoustic insulation (dB)

DESIGN

CUT WINDOW PROFILES REMINISCENT OF INDUSTRIAL STEELWORK ARE USED IN MODERN ARCHITECTURE

REYNAERS SLIMLINE 38

This is a thermally insulated system designed for inward and outward opening windows. The minimalist design is emphasised by the invisible drainage system, which does not use gaskets on the outside of the window. This system has anti-burglary properties in class 2. CS 38-SL can also be used in buildings with a steel structure **to maintain the original appearance of windows and doors.**



76-99	Frame installation depth (mm)	up to 1600Pa class C4	Wind load resistance
72-86	Sash installation depth (mm)	up to 750Pa class E750	Watertightness
up to 600Pa class 4	Air permeability	45 dB	Acoustic insulation (dB)



VARIOUS
SOLUTIONS



PATIO SYSTEMS

The modern world aims to create open spaces to increase the usable area of a building. Patio doors are structures that are ideal for a living room overlooking a terrace or garden.

The most popular among customers are lift-and-slide doors and folding doors, which make it possible to **create huge glass surfaces** that maximise the amount of sunlight inside, giving comfort and pleasure from the amazing appearance of the house. The structures are built up from profiles providing large-format glazing while optimising the space created up when open.

Folding systems allow for fuller opening of the space - after folding the sashes, the free space is as much as 90% of the window opening width. In the case of sliding systems with fixed element, we usually obtain 50-60% of the open space.

On the other hand, when the doors are closed, it is the sliding systems that **offer an unobstructed view**, as they consist of fewer, wider elements with larger glazed surfaces. Folding doors have more sashes, each with its own frame, which in turn means more visible profiles.

THE HIGHEST DEGREE OF AESTHETICS

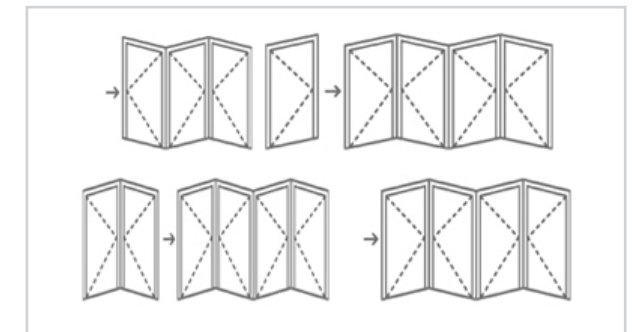
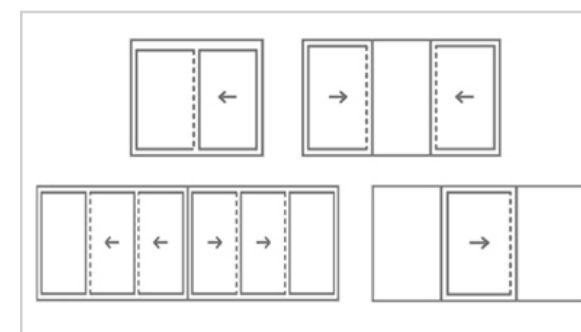

TIMELESS ELEGANCE



CORTIZO 4600

It is a lift and slide door system that is characterised **by very high thermal insulation** with a transmission rate (U-value) of 0.9 (W/m²K).

This system is based on a mechanism that allows the sash to be raised when opening and lowered when closing. The 4600 system is extremely durable yet lightweight, guaranteeing easy opening and ensuring the panel slides perfectly along the stainless steel track.



160,6-251	Frame installation depth (mm)
78	Sash installation depth (mm)
(L) = 3300 (H) = 3300	Maximum dimensions / sash (mm)
400	Maximum weight / sash (kg)

CORTIZO 4900

This solution is recommended for **countries with a mild climate**, such as England. It is a system of sliding windows and doors with a **modern design**, which consists of straight profile edges and a central mullion only 35 mm wide.

For sashes weighing up to 240 kg, maximum dimensions are 2200 mm (H) x 2600 mm (W).



70-126	Frame installation depth (mm)
48	Sash installation depth (mm)
(L) = 2200 (H) = 2600	Maximum dimensions / sash (mm)
240	Maximum weight / sash (kg)

INDIVIDUAL STYLE OF A BUILDING



Minimalist sliding door systems are designed to create individual style in a building by designing huge glazing with a glass surface area of 94%. Such solutions allow for **maximum interior illumination** while **minimising visible aluminium sections**. These solutions make it possible to meet the requirements of contemporary architecture.

It is possible to open up the space as much as possible using a pocket solution. When the sashes are pulled apart, all elements are hidden in the wall and nothing obstructs the view. Another interesting solution is a so-called 90° open corner, where there is not any post after pulling apart, only an open space.

Various configurations of 1 sash+fix, and 2,3, 4 or 6 sashes are available with maximum height or width dimensions of up to 4000 mm/sash.

CORTIZO COR VISION +

It is possible to fully hide the frames around the perimeter, while the width of the central post is only 25mm. The possibility of automatic opening has been introduced, which allows the sash weight to be increased to 700kg (up to 400kg when opening manually).

The rollers are located in the frame and the sashes have a reinforced inox steel rail, which makes the slide more gentle.



180-278	Frame installation depth (mm)
25	Center post width (mm)
(L) = 4000 (H) = 4000	Maximum dimensions / sash (mm)
400/700	Maximum weight / sash (kg)

REYNAERS HI-FINITY

The durable structure allows the installation of glass elements weighing up to 750kg and fixed elements weighing up to 1200kg. Provides excellent insulation thanks to the possibility of dual and triple glazing, thus giving a feeling of warmth and comfort.

There is a possibility of using a recessed threshold, where we do not have any elevation between the interior and the exterior which guarantees the best appearance and comfort in use.

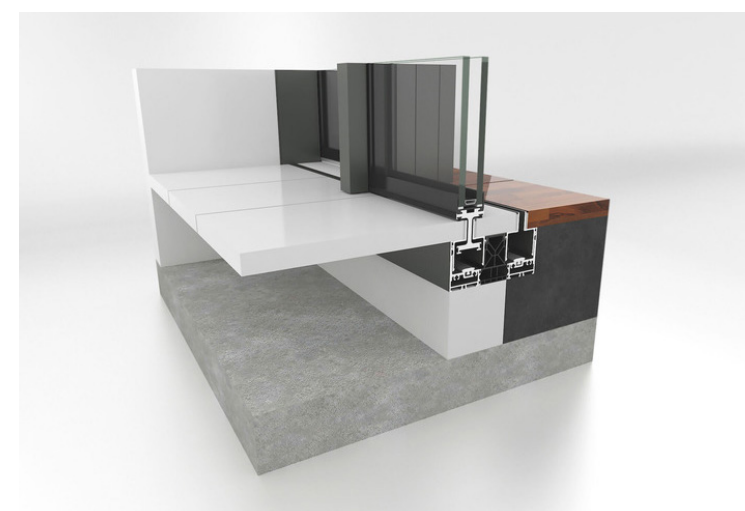

147-282	Frame installation depth (mm)
35	Center post width (mm)
(H) = 3500	Maximum dimensions / sash (mm)
300/750 /1200	Maximum weight / sash (kg)

FOLDING DOORS

Folding doors are a system that creates an opening with a **perfect view of the surroundings, where the line between the house and the garden or terrace is completely blurred.** These systems offer **different configurations**, including solutions with standard opening doors: for example, you can fold all the sashes to one side or design the structure so that the sashes fold inwards or outwards. It is also possible to choose whether the sashes fold inwards or outwards.



NO BOUNDARIES



CORTIZO BI-FOLD

The folding door system from Cortizo is characterised by its versatility - it provides a wide range of configurations with up to 14 sashes, making it possible to create even and odd compositions, opening inwards and outwards.

In order to facilitate access to the rooms, the bottom frame is designed as recessed, so that the threshold remains completely hidden.



70	Frame installation depth (mm)
78	Sash installation depth (mm)
(L) = 1200 (H) = 3000	Maximum dimensions / sash (mm)
14	Maximum number of sashes



REYNAERS CF77

Concept Folding® 77 combines a high degree of insulation and comfort with maximum solar transmittance and an amazing appearance.

Four door threshold solutions are available: with high tightness performance; with intermediate tightness performance; with a low threshold; with a flat threshold to meet all aesthetic and practical requirements.

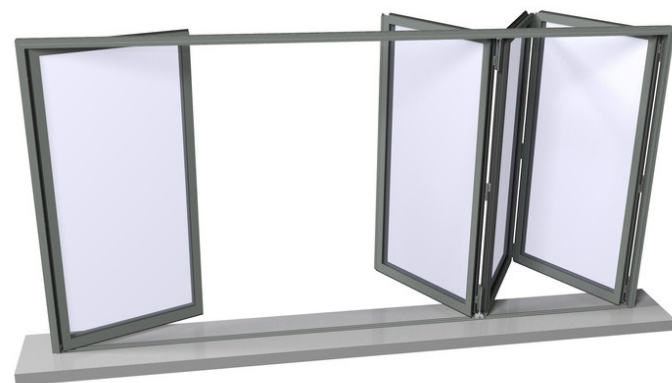

77	Frame installation depth (mm)
77	Sash installation depth (mm)
(L) = 1200 (H) = 3000	Maximum dimensions / sash (mm)
14	Maximum number of sashes

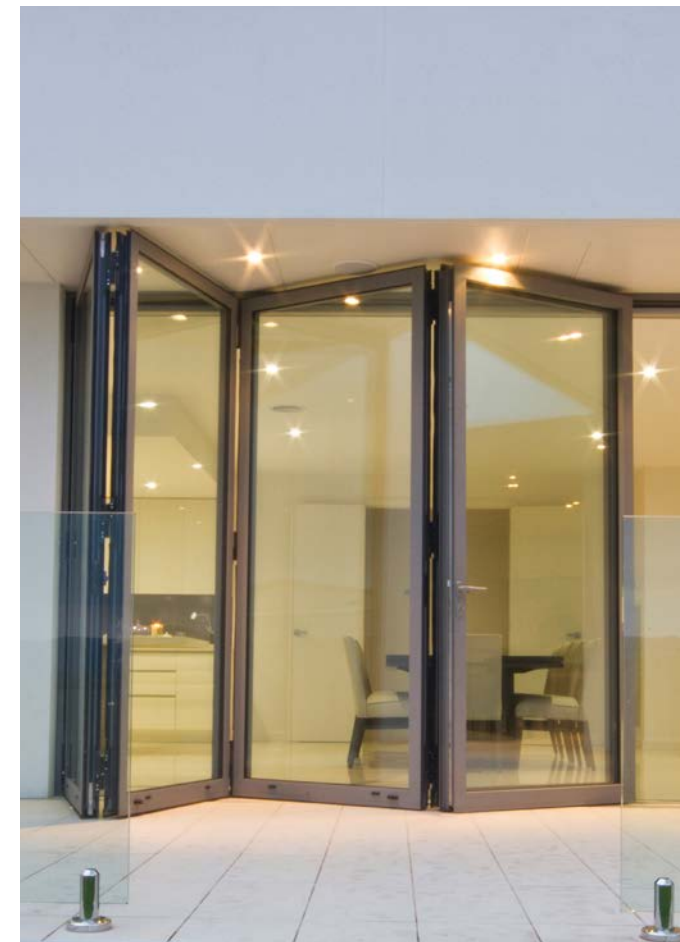



ENTRY DOORS

Aluminium entrance doors are a **solution for customers with unique demands**. Both lightweight and rigid door construction, uniform door leaf surface and a wide range of door panel designs ensure our door joinery - due to its individuality - suits the architecture of single-family houses in an interesting way.

There are many types of doors and equipment options:

- Single door: inward or outward opening.
- Double door: composed of two sections with a specific opening sequence - active leaf and passive leaf fitted with a bolt or central locking mechanism.
- Pivot door: the door revolves around a central axis so that it can be opened both inwards and outwards.

DOORS THAT EXCEED CUSTOMER'S EXPECTATIONS



EXCELLENT TIGHTNESS AND INSULATION



PIVOT DOORS

Pivot doors are an interesting architectural solution, a unique alternative to standard entrance doors. The axis of rotation of the leaf is offset from the frame and as a result, even when very large and heavy, the door is easy to open and close. A revolving door leaf can weigh up to 500 kg. Pivot doors allow the construction of very high and wide entrance doors, also with a fanlight.

Pivot doors are available in both panelled and glazed versions, allowing you to choose a solution to suit any project.

PANEL DOORS

Panel doors are the perfect solution as an entrance door to your home. With insulated, robust profiles, this door system meets all modern requirements for security, thermal insulation and stability. A full range of locks and fittings are available as accessories.

Aluminium panels are available in various patterns and colors. Different techniques of milling in numerous shapes, decorative applications and the use of insulated glass give countless combinations and variants.



(L) = 2500 (H) = 4000	Maximum leaf dimensions (mm)
600 Pa	Max. air permeability
150 Pa	Watertightness
1200 Pa	Wind load resistance
RC2	Burglar resistance



(L) = 1400 (H) = 3000	Maximum leaf dimensions (mm)
600 Pa	Max. air permeability
300 Pa	Watertightness
1200 Pa	Wind load resistance
RC2/RC3	Burglar resistance

GLASS FACADES
ARE A PERFECT TOOL TO
DEVELOP CONTEMPORARY
ARCHITECTURE
AND TO BRING THE BOLD
VISIONS OF DESIGNERS
TO LIFE



CURTAIN WALLS (FACADES)

Mullion-transom systems allow unlimited freedom of design and maximum insolation of interiors. Aluminium facades are used to construct glazed elevations of buildings, such as: banks, hotels, office buildings, car showrooms and single-family houses. They are also used to make spacious structures and roof glazing, in order to provide **adequate lighting for the interiors**, giving comfort to users.

We offer design solutions that create the possibility of:

- building a facade in fire resistance class EI30 and EI60;
- applying solutions for the lintel-window sill strip with tightness and fire insulation of EI60;
- using filling with a thickness of 38-64 mm, including transparent and opaque glass;
- assembling swing, sliding and pivot doors;
- installing side by side top-hung windows, opening independently;
- using various types of external decorative elements;
- making a "horizontal" or "vertical" line version;
- bending profiles.



FREEDOM TO CHOOSE
SHAPE AND STYLE

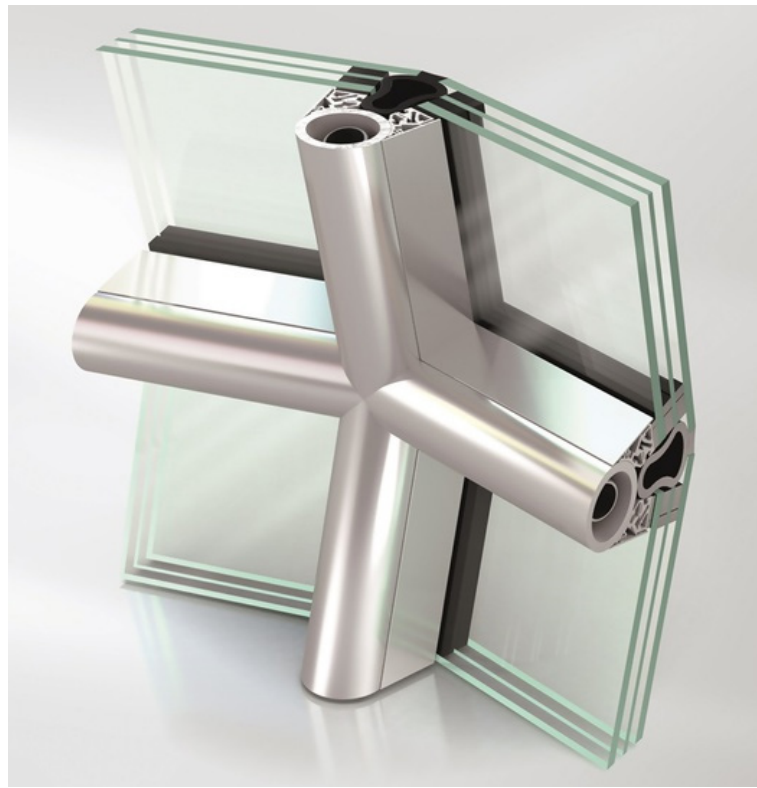

SCHÜCO PARAMETRIC

This is the consistent development of Schüco facade system where the geometry of the building can be freely shaped on the basis of parametric models.

The innovative system solution for the design of facades with complex geometries meets the highest architectural requirements, based on parametric design methods and synchronised process chains. Schüco Parametric is an elegant structural facade (Structural Glazing) with extremely narrow joints for single and double glazing. The system features high thermal insulation with Uf values of up to 0.5 W/(m²K).

Based on parametric design methods and a systematic approach, this concept offers the

architect a wide range of possibilities, gives the contractor certainty, and allows the customer to control costs.

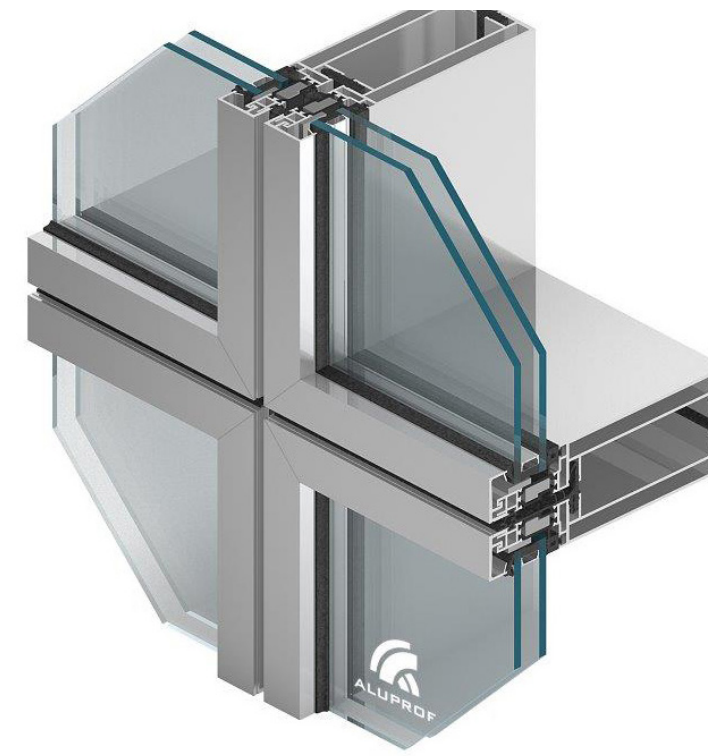

ALUPROF MB-SE 75

The main purpose of the MB-SE75 curtainwall system is fast assembly and disassembly of external scaffolding during construction. The MB-SE75 facade construction consists of segments fastened to the supporting structure of the building and joined with one another. Prefabrication of the elements takes place in the production workshop, which leads to a significant increase in the quality of the final product.

The element facade system meets the highest technical and aesthetic requirements. The construction made in this system is characterised by the visible width of sections of 75 mm, with a narrow 9 mm dilatation gap between individual segments.

Flexibility between the individual components of the system allows the structure to be optimally adapted to the specific object requirement.



SCHÜCO FWS 35 PD

A new facade system with extremely narrow profiles for almost unlimited visibility. This innovative aluminium curtainwall is based on extremely slim profiles with a front width of just 35 mm, while still providing passive levels of thermal insulation. It therefore provides a solution to the need of combining aesthetic requirements with sophisticated technology.

The system is certified by the Passive House Institute (Uf value of up to 0.90 W/(m²K) and has the option of installing double glazing units up to 52 mm thick - in two thermal insulation variants: with HI (High Insulation) or SI (Super Insulation). In addition, the system provides research-proven burglary protection (up to class RC2).

The Schüco FWS 35 PD panorama facade system is perfect, particularly for elegant glazing in high-class residential and commercial buildings.



TOP QUALITY COMPONENTS
IN COOPERATION WITH SWISS SUPPLIERS



EXTERIOR BLINDS

Exterior blinds are a **highly efficient solar protection system**, which at the same time changes the appearance of elevations giving them an interesting and modern look.

There are several types of blinds, each characterised by a different shape of lamellas. This, combined with modern aluminium joinery, makes the product extremely aesthetic.

Exterior blinds:

- maintain natural light in rooms;
- reduce energy costs;
- can be fitted with an anti-insect net which provides effective protection against insects;
- have sections of different widths with adjustable tilt angles;
- can be fixed to a facade, load-bearing walls or windows. Intelligent solutions allow for remote control;
- enhance the prestige of a building as an exclusive product.

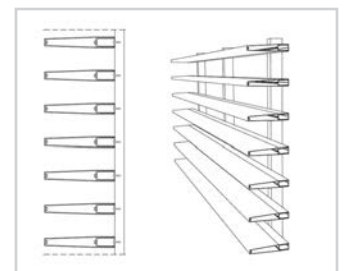
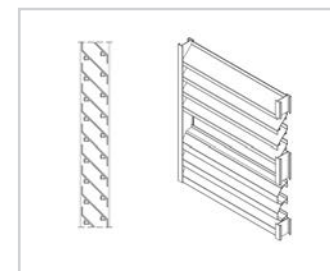
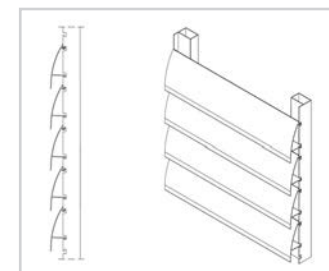
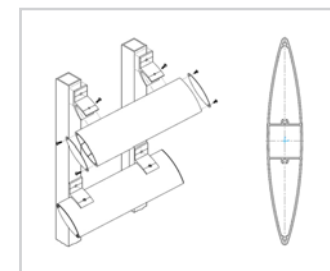

SHUTTERS

Shutters are a perfect solution combining the durability of aluminium with traditional design. Each shutter is made from the highest quality aluminium, characterised by high rigidity with lightweight and slim structure at the same time.

Three types of shutters are available: tilt, tilt-fold and sliding.

Additionally, each shutter is offered with different lamellas:

- movable with possibility of light and air flow regulation;
- fixed downwards at one angle.

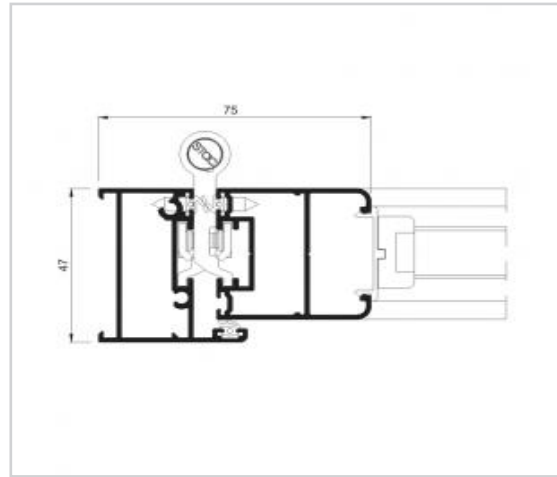

MOSQUITO NETS

Mosquito nets are a covering system mounted to windows, doors or sliding doors, which protects against insects and at the same time does not obscure the view. Thanks to their construction mosquito nets do not block the possibility of opening or closing windows or doors.

The system is compatible with all offered doors, windows and sliding doors.

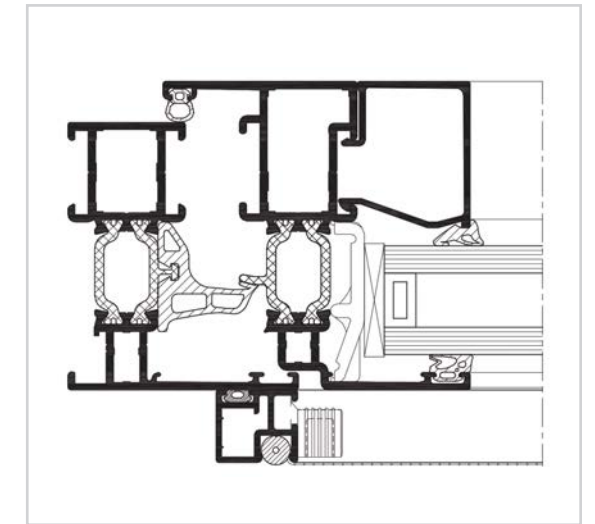
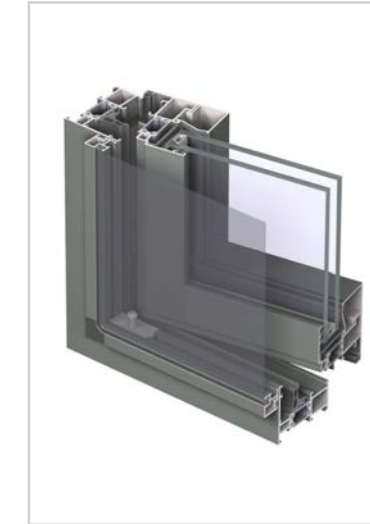

PERFECT FIT FOR INDIVIDUAL STYLE



ACCESSORIES

Accessories do not only complement the appearance of joinery. Its usability depends on them to a large extent. Both window and door joinery should first and foremost be functional.

Safety of use will depend on handles and fittings while thermal insulation will be provided by the use of appropriate glass.

Ventilation, so important in recent years, will be taken care of by a properly selected air-vent.



PULL HANDLES

SELECTED MODELS

A wide range of handle and pull handle designs will be a perfect complement to any project.

Pull handles length (mm):

- 300
- 400
- 500
- 580
- 600
- 800
- 1000
- 1200
- 1400
- 1600
- 1800
- 2000
- 2200



WALA P45 TUBE PULL HANDLE

The pull handle is made of 304 or 316 stainless steel. Brushed (default), but can also be sandblasted (max. 1000mm) or polished. The steel pull handles are made of tubes with Ø30, Ø40 or Ø50 cross-sections.



WALA Q45RX 50X25 SQUARE PULL HANDLE

The pull handle is made of 304 or 316 stainless steel. Brushed (default), but can also be sandblasted (max. 1000mm) or polished. The steel pull handles are made of tubes with 25x25, 40x20, 40x40 or 50x25 cross-sections.



WALA DP45-S2 SQUARE PULL HANDLE

The pull handle is made of 316 stainless steel. Brushed (default), but can also be sandblasted (max. 1000mm). The steel pull handles are made of tubes with Ø45x25 cross-sections.



WALA P45B ARCH PULL HANDLE

The pull handle is made of 304 stainless steel. Brushed (default), but can also be sandblasted (max. 1000mm) or polished. The steel pull handles are made of tubes with Ø30 cross-section.



WALA K1 FLUSH PULL HANDLE

The pull handle is made of 304 stainless steel. Brushed (default), but can also be sandblasted (max. 1000mm) or polished. The steel pull handles are made of tubes with Ø30 cross-section.



DETAILS MATTER

HANDLES

SELECTED MODELS



H2 HANDLE



H3 HANDLE



H6S26 HANDLE



H7S26 HANDLE

ACCESS CONTROL SYSTEM

SELECTED MODELS



RFID SCANNER
IN PULL HANDLE



LED STRIP
IN PULL HANDLE



EKEY CONTROL
SYSTEM IN DP10-S2
PULL HANDLE



KEYBOARD IN
IDENCOM Q10 40X40
PULL HANDLE

GLAZING

Glass types:

- standard single-chamber glass pane;
- two-chamber glass pane - a solution increasing thermal parameters of the window;
- protective glass – a laminated glass, which consists of two glass panes and several layers of PVB foil, will effectively reduce the risk of burglary;
- safe glass - it provides protection against injury wherever, due to the conditions of use, there is a risk of glass breakage;
- sun protection glass - externally covered with a special foil, which optimizes the temperature in a room and reduces the UV transmittance;
- soundproof glass - depending on the construction - the glass achieves acoustic insulation in the range of $R_w = 28-53$ dB, which allows for effective protection against noise;
- ornament glass - should allow light to enter the room, increasing the warmth and depth of its function, while maintaining privacy.



ORNAMENTS



ALTDEUTSCH COLORLESS



ALTEDEUTSCH BROWN



ATLANTIC

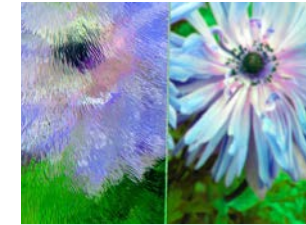

CHINCHILLA



CREPI



DELTA MATTE



FLOAT MATTE



KATHEDRAL



MASTER LIGNE



INCREASED USE OF GLASS
AS A MODERN DECORATIVE MATERIAL
LEADS TO MEETING SPECIFIC NEEDS

BREATHE FRESH AIR



AIR-VENTS

Air vents are one of the most important elements of the ventilation system. In particular, if the rooms are equipped with gravity or mechanical exhaust ventilation, then the air-vents become the only source of air.

2 (300Pa)	Air infiltration	5C (2000Pa)	Wind load resistance
650 Pa	Water tightness	2Pa+50 +/-m ³ /h/m	Air flow

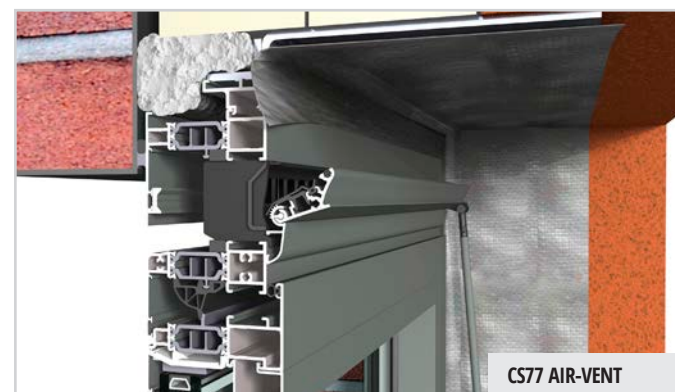
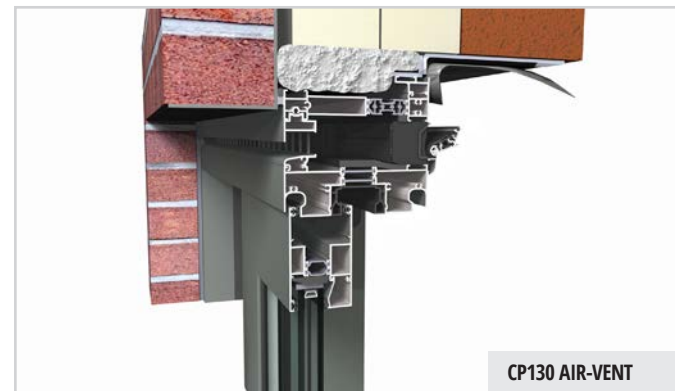

PROJECTS

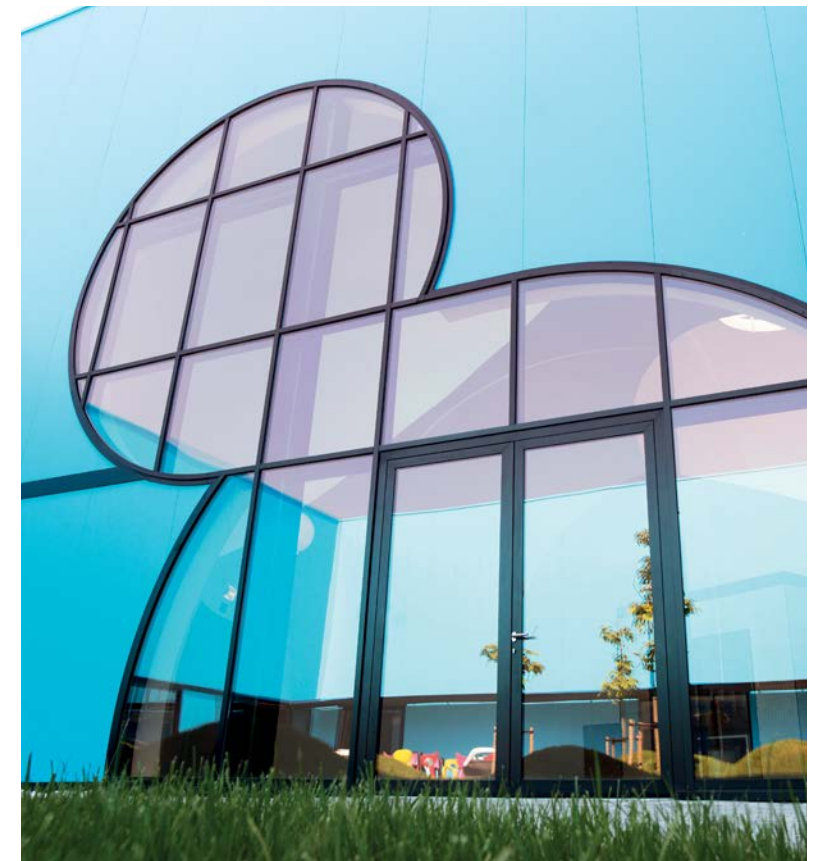

IDEAS THAT INSPIRE

ABOUT US



GVG specialises in the production and assembly of modern aluminium joinery. From the beginning, we were only focused on the production of high-quality products, which is why we rely on system solutions from Schüco, Reynaers, Cortizo, Aluprof.

We consider each project and request individually. We are able to create even the most unique solution tailored to the requirements of a specific investment.

Aluminium and glass are the basic materials that we work with to create modern and unique architecture.

We successfully combine rich tradition resulting from many years of experience with innovative technical and technological solutions. The organization of work and the factory production control allow us to find newer solutions to maintain high quality products.

OUR PARTNERS



OUR LOCATION



WE MANUFACTURE

- windows
- entry doors
- internal doors
- sliding windows
- folding doors
- curtain walls (facades)

WE GUARANTEE

- amazing design
- high quality
- energy efficiency
- product durability
- precision

WE HAVE

- modern machinery
- system of factory production control
- high-quality components
- well-earned reputation

WE OFFER

- technical support
- comprehensive assistance
- competitive prices
- all required technical permits



GVG Aluminium
44-280 Rydułtowy
Orłowska 7
Poland

Office
tel. +48 516 048 649
e-mail: info@gvg.com.pl

Export department
tel. +48 511 207 217
e-mail: export@gvg.com.pl



GVG Aluminium
44-280 Rydułtowy ul. Orłowska 7
Poland
info@gvg.com.pl
www.gvg.com.pl
tel. +48 511 207 217